

100SA SERIES BRAKE CALIPERS

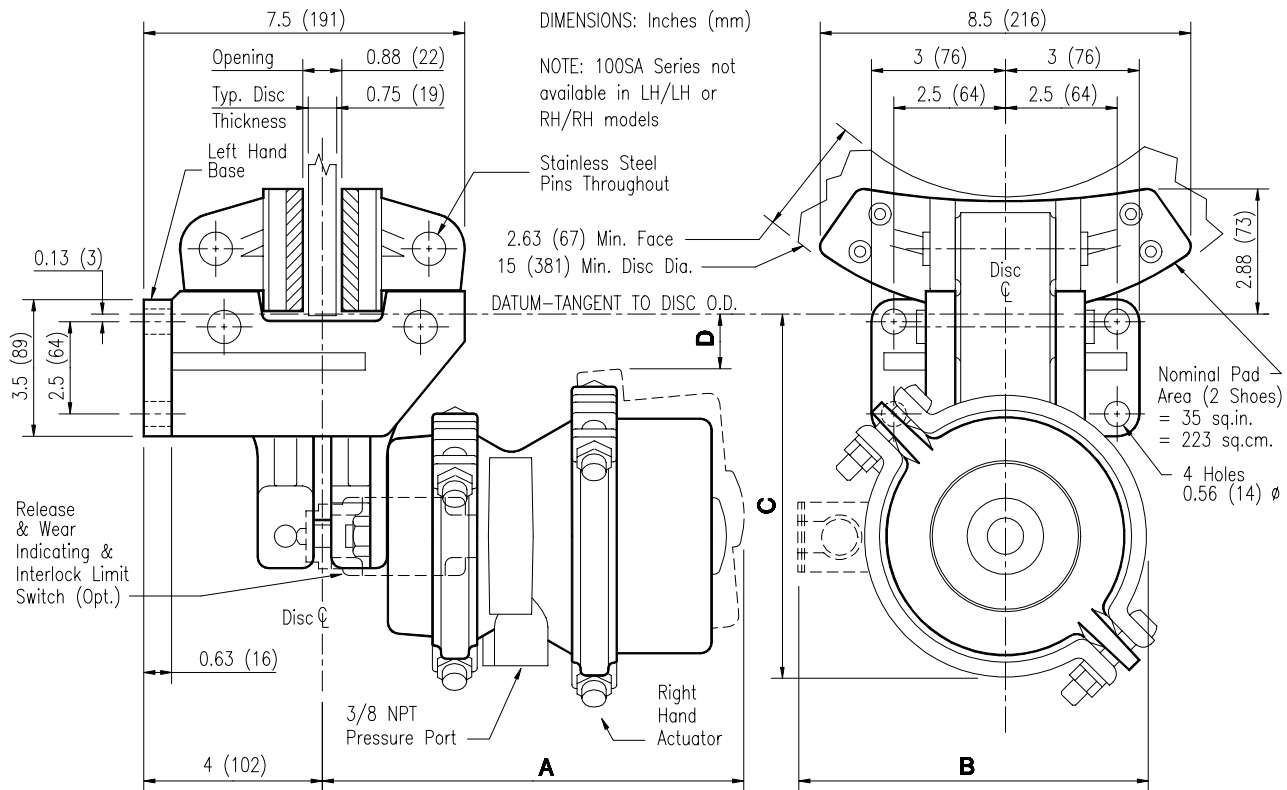

SPECIFICATIONS

MODEL NO.	APPLIED FORCE lb/N	WEIGHT lb/kg	ACTUATOR SPECIFICATIONS				DIMENSIONS in./mm				MAXIMUM DYNAMIC BRAKE TORQUE lb-ft/Nm @ Disc Diameter in./mm			
			AIR PRESSURES psi/kPa			MAX. VOL. in ³ /cm ³	A	B	C	D	15/380	35/890	55/1400	75/1910
			RELEASE	HOLD-OFF	MAXIMUM									
1012FA	2930 13000	40 18	82 565	80 552	120 827	26 426	8.8 222	8 203	7.8 198	1.4 35	764 1040	1990 2690	3210 4350	4430 6010
1016FA	4530 20200	44 20	85 586	83 572	120 827	44 721	9.5 241	8.4 213	8.1 206	1.1 28	1180 1600	3070 4160	4960 6720	6850 9290
1024FA	6400 28500	48 22	90 621	88 607	120 827	88 1442	10.3 260	8.8 224	8.6 218	0.6 15	1670 2260	4330 5880	7000 9490	9670 13100

Torque Formulae, lb-ft:

$$\text{Dynamic Torque} = AF \times 0.50 \times (D-2.56) / 24$$

$$\text{Static Torque} = AF \times 0.40 \times (D-2.56) / 24$$

Torque Formulae, Nm:

$$\text{Dynamic Torque} = AF \times 0.50 \times (D-65) / 2000$$

$$\text{Static Torque} = AF \times 0.40 \times (D-65) / 2000$$

AF = Applied Force

D = Disc Diameter

The above specifications are for estimating purposes only and may be changed without notice. More complete details and certified drawings are available upon request. Please specify caliper handing and desired disc thickness when enquiring or ordering.

We prefer to quote each specific application to ensure the suitability of a caliper and disc selection. Special purpose calipers, if not already available, may be designed to your requirements. Your enquiries will be welcomed and shall receive prompt attention.

Johnson industries / elevanja Ltd

Vancouver BC Canada -- Tel: 604 940 4555 Fax: 604 940 4565

Toronto ON Canada -- Tel: 416 213 9991 Fax: 416 213 9992

Bridgwater SOM England -- Tel: 01278 456411 Fax: 01278 429949

**100SA SERIES SIDE-MOUNTED CALIPERS
SPRING-APPLIED & AIR RELEASED**

BY: MF

DATE: 91/11/12

DWG. NO.

SC: NTS

REV.:

BC100SA-1.1

PATH: dbr/sls/bc100sa